

Right Clamp. Right Price. Right Now.

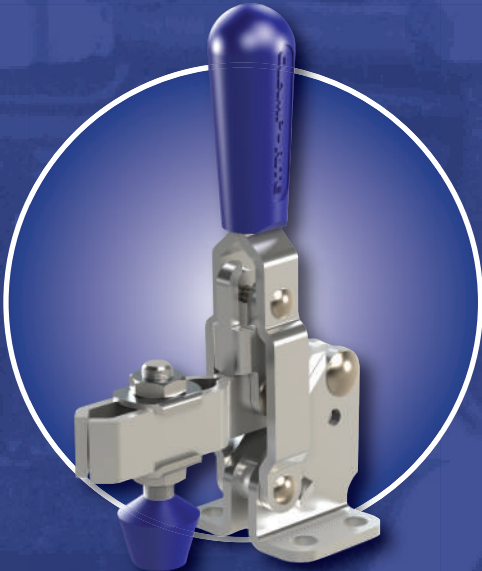

CLAMP-RITE

www.clamp-rite.com

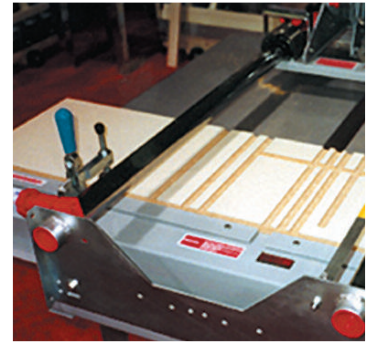
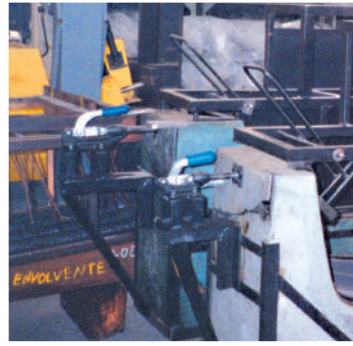
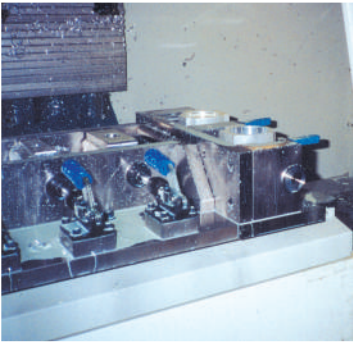
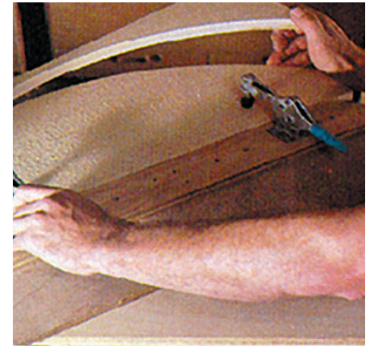
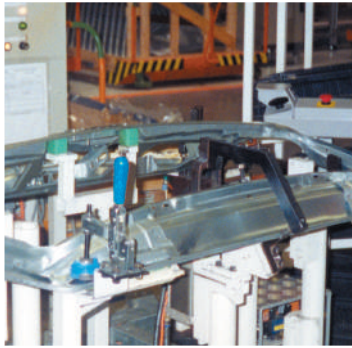

Clamp-Rite Toggle Clamps provide unmatched value by delivering:

- Quality materials and workmanship
- Industry standard designs
- The most popular sizes and styles

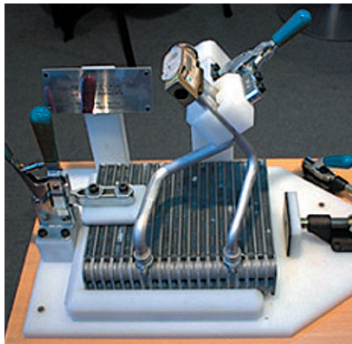
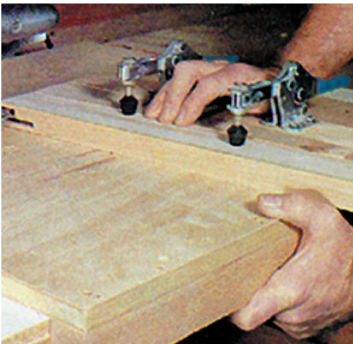

Vertical Handle Toggle Clamps



Series 1101	4
Series 1102	5
Series 1107	6
Series 1110	7
Series 1147	8
Series 1167	9
Series 1117	10

Horizontal Handle Toggle Clamps



Series 1405	11
Series 1415	11
Series 1425	12
Series 1435	12
Series 1605	13

Latch Type Toggle Clamps



Series 1223	14
Series 1275	15
Series 1224	16
Series 1251	17
Series 1201	18

Push/Pull Action Toggle Clamps



Series 1301	18
Series 1302	19
Series 1305	20
Series 1303	20
Series 1309	21
Series 1310	21
Series 1307	22

Accessories	23
--------------------------	-----------

Series 1101

Specifications

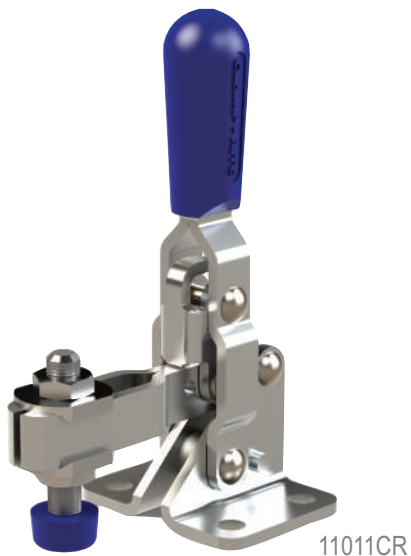
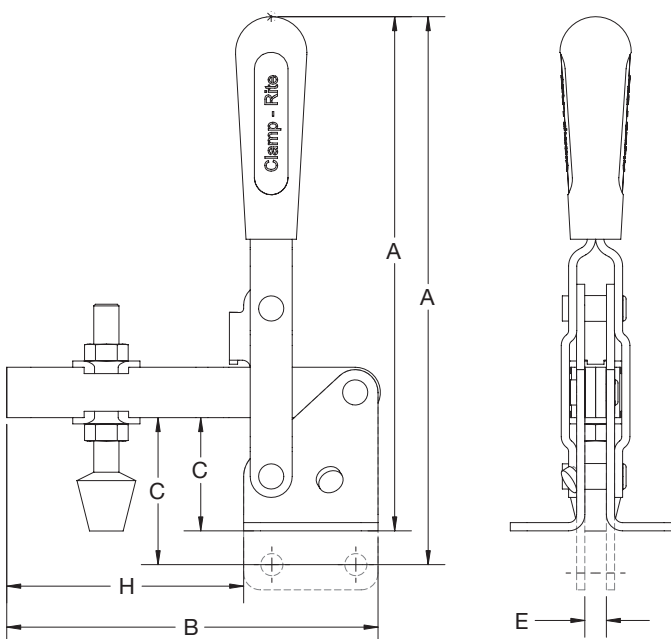
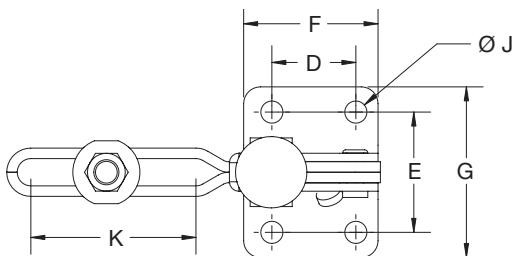
Bar Opens: **110°**Handle Opens: **61°**Spindle Supplied: **19525CR**Straight Base
11021CR

11011CR

Model	Holding Capacity	Weight	Description	A	B	C	D	E	F	G	H	J	K
Metric	N/lb.	Kg/lb.		mm/in.									
11011CR	440	0.07	Flanged Base, U-Bar	77	52	15.8	15.7	24	25.4	33.5	26.6	4.5	18.5
	100	0.16		3.03	2.05	0.62	0.62	0.94	1.00	1.32	1.05	0.18	0.73
11012CR	440	0.07	Straight Base, U-Bar	83.5	52	22.4	15.7	3.8	25.4	-	26.6	4.5	18.5
	100	0.16		3.29	2.05	0.88	0.62	0.15	1.00	-	1.05	0.18	0.73

Dimensions and technical information subject to change without notice.

Series 1102

Specifications

Bar Opens:	96°
Handle Opens:	62°
Spindle Supplied:	19630CR

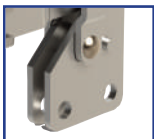

Straight Base
11022CR
11025CR



Solid Bar
11020CR

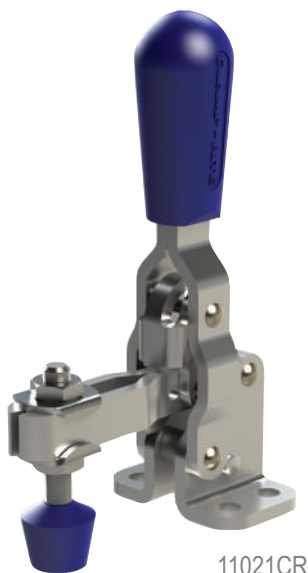
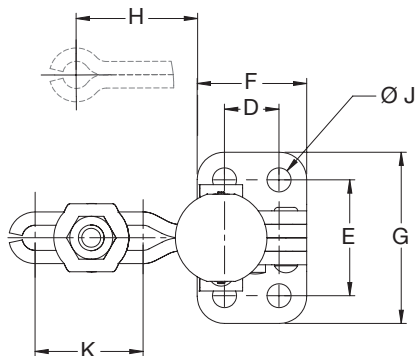

11021CR

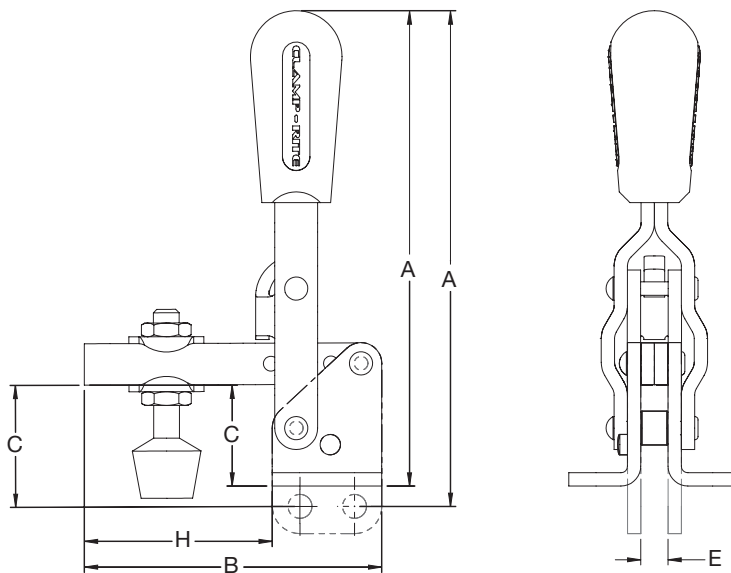

Model	Holding Capacity	Weight	Description	A	B	C	D	E	F	G	H	J	K
Metric	N/lb.	Kg/lb.		mm/in.									
11020CR	890	0.16	Flanged Base, Solid Bar	110.7	58.6	23.7	12.7	27	25.5	39.9	33.1	5.6	-
	200	0.35		4.36	2.31	0.93	0.5	1.06	1.00	1.57	1.30	0.22	-
11021CR	890	0.16	Flanged Base, U-Bar	110.7	69.2	23.5	12.7	27	25.5	39.9	43.7	5.6	25.1
	200	0.35		4.36	2.73	0.92	0.5	1.06	1.00	1.57	1.72	0.22	0.99
11022CR	890	0.16	Straight Base, U-Bar	115.5	69.2	28.2	12.7	6.4	25.5	-	43.7	5.6	25.1
	200	0.35		4.55	2.73	1.11	0.5	0.25	1.00	-	1.72	0.22	0.99
11025CR	890	0.16	Straight Base, Solid Bar	115.5	58.6	28.2	12.7	6.4	25.5	-	33.1	5.6	-
	200	0.35		4.55	2.31	1.11	0.5	0.25	1.00	-	1.30	0.22	-

Dimensions and technical information subject to change without notice.

Series 1107

Specifications

Bar Opens: **102°**Handle Opens: **57°**Spindle Supplied:* **19835CR**

*Solid Bar versions supplied with bolt retainer.

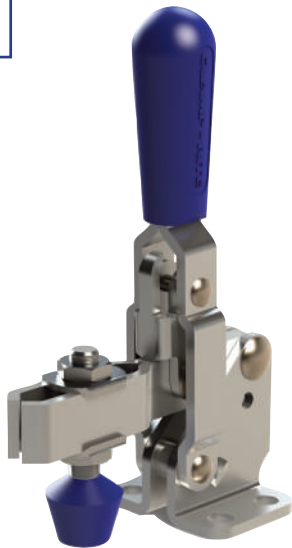
Straight Base
11072CRSolid Bar
11074CRT-Handle
11073CR

11071CR

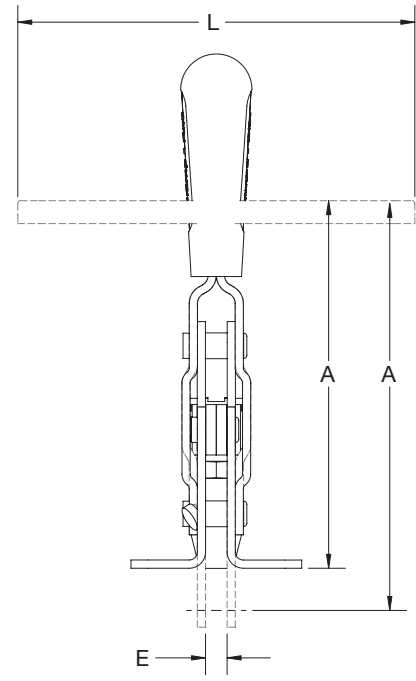
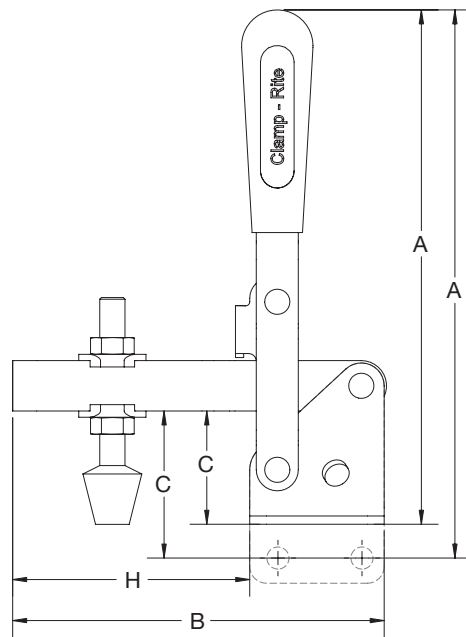
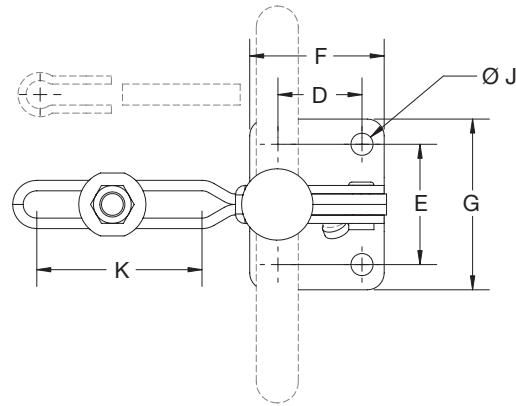

Model	Holding Capacity		Weight	Description	A	B	C	D	E	F	G	H	J	K
	N/lb.	Kg/lb.												
11018CR	1670	0.30	0.30	Flanged Base, Long U-Bar	143.2	137.1	31.9	19.1	31.8	35.1	44.6	97.5	7.1	76.2
	375	0.67			5.64	5.4	1.26	0.75	1.25	1.38	1.75	3.84	0.28	3.00
11071CR	1670	0.30	0.30	Flanged Base, U-Bar	143.2	111.7	31.9	19.1	31.8	35.1	44.6	72.1	7.1	50.8
	375	0.67			5.64	4.4	1.26	0.75	1.25	1.38	1.75	2.84	0.28	2.00
11072CR	1670	0.35	0.35	Straight Base, U-Bar	150.8	111.7	39.3	19.1	6.4	35.1	-	72.1	7.1	50.8
	375	0.78			5.94	4.40	1.55	0.75	0.25	1.38	-	2.84	0.28	2.00
11073CR	1670	0.37	0.37	Flanged Base, U-bar, T-Handle	104.1	116.8	31.2	19.1	31.8	35.1	45.0	72.4	6.9	53.3
	375	0.82			4.10	4.60	1.23	0.75	1.25	1.38	1.77	2.85	0.27	2.10
11074CR	2220	0.34	0.34	Flanged Base, Solid Bar	143.2	95.9	31.8	19.1	31.8	35.1	44.6	56.3	7.1	-
	500	0.75			5.64	3.78	1.25	0.75	1.25	1.38	1.75	2.22	0.28	-

Dimensions and technical information subject to change without notice.

Series 1110

Specifications

Bar Opens: **105°**

Handle Opens: **58°**

Spindle Supplied:* **3/8-16 x 3.50**

*Solid Bar versions supplied with bolt retainer.

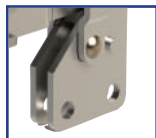

Straight Base
11107CR



Solid Bar
11104CR
11107CR

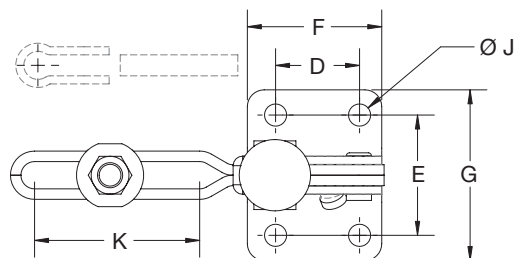

11101CR

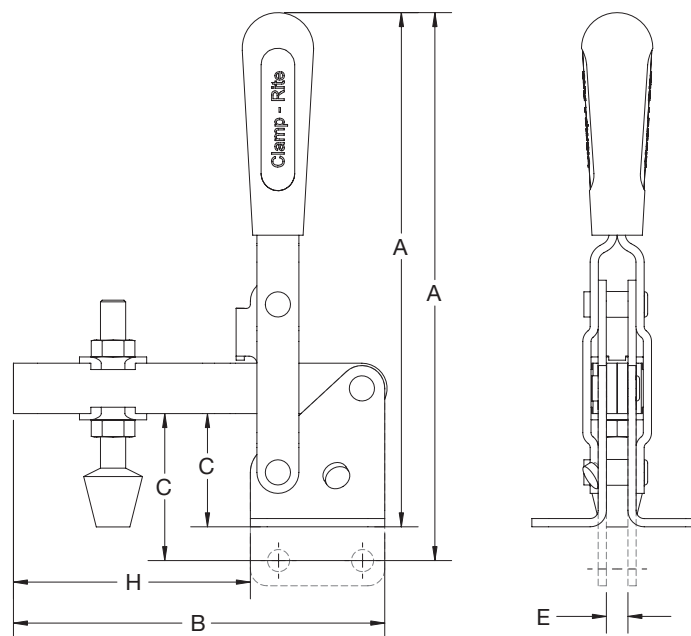

Model	Holding Capacity		Weight	Description	A	B	C	D	E	F	G	H	J	K
	N/lb.	Kg/lb.												
11101CR	2670	0.59	600	Flanged Base, U-Bar	196	139.4	42.4	31.8	45.2	49.3	64.5	90.2	8.3	59.4
		1.29			7.71	5.65	1.67	1.25	1.8	1.94	2.55	3.56	0.31	2.31
11104CR	3340	0.68	750	Flanged Base, Solid Bar	200.4	142	32	31.8	46.0	49.3	65	89.7	7.9	-
		1.5			7.89	5.59	1.26	1.25	1.81	1.94	2.56	3.53	0.31	-
11107CR	3340	0.68	750	Straight Base, Solid Bar	214.9	142	54.9	31.8	8.9	49.3	-	91.2	7.9	-
		1.5			8.46	5.59	2.16	1.25	0.35	1.94	-	3.59	0.31	-

Dimensions and technical information subject to change without notice.

Series 1147

Specifications

Bar Opens: **96°-135°**Handle Opens: **67°-70°**Spindle Supplied: **19310CR**

*for U-Bar versions only.

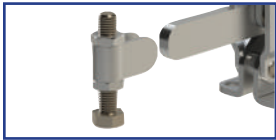
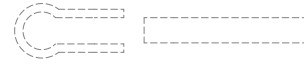
Solid Bar
11474CR

11474CR

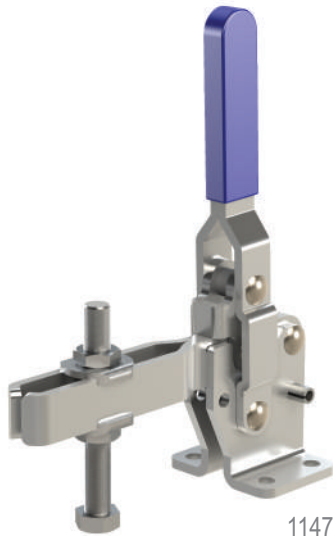
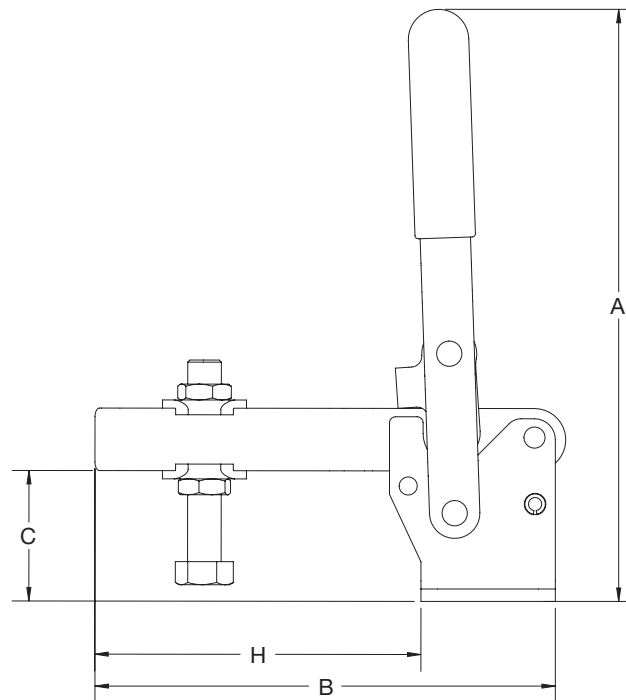
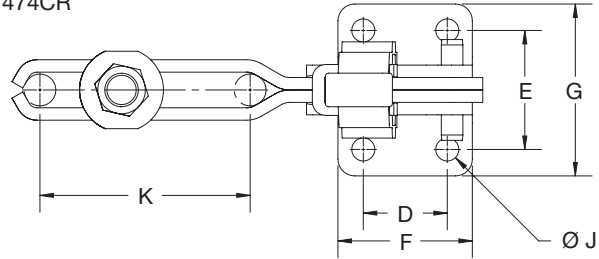

11471CR

Model	Holding Capacity		Weight	Description	A	B	C	D	E	F	G	H	J	K
	N/lb.	Kg/lb.												
11471CR	4400	1.24		Flanged Base, U-Bar	223.8	175.0	49.5	31.8	45.0	50.8	65.0	123.7	8.9	75.7
	1000	2.76			8.81	6.89	1.95	1.25	1.77	2.00	2.56	4.87	0.35	2.98
11474CR	4400	1.24		Flanged Base, Solid Bar	223.8	180.9	50.8	31.8	45.0	50.8	65.0	130.1	8.9	-
	1000	2.76			8.81	7.12	2.00	1.25	1.77	2.00	2.56	5.12	0.35	-

Dimensions and technical information subject to change without notice.

Series 1167

Specifications

Bar Opens:	140°
Handle Opens:	60°
Spindle Type:	1/2-13 x 4.50

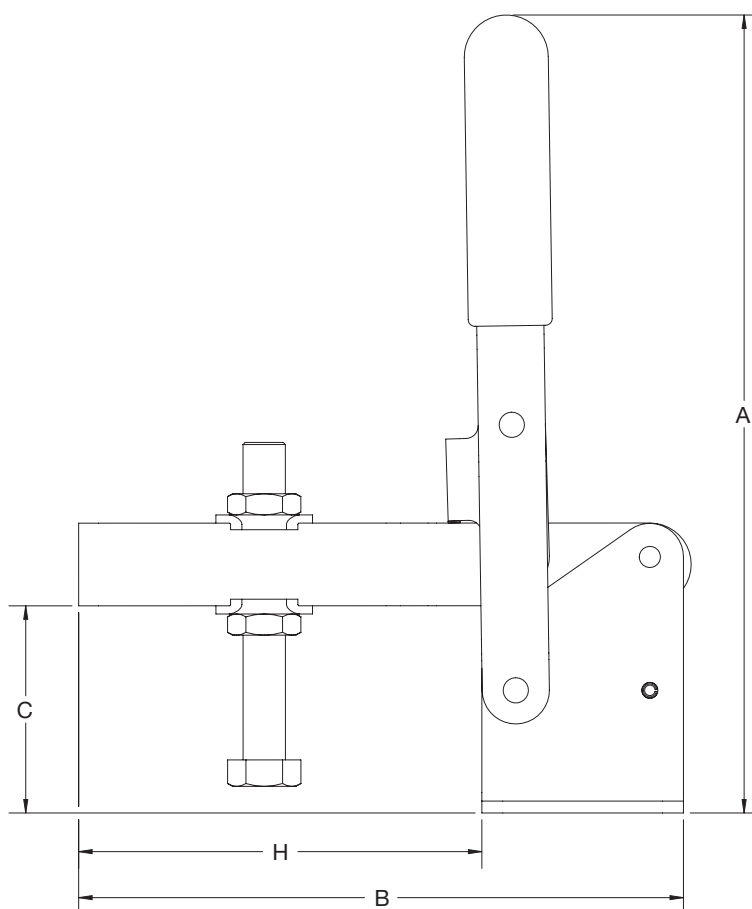
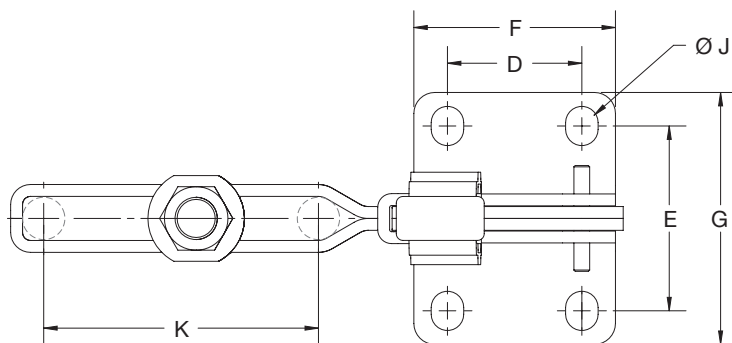

Model	Holding Capacity	Weight	Description	A	B	C	D	E	F	G	H	J	K
	N/lb.	Kg/lb.		mm/in.									
11671CR	5340	2.54	Flanged Base, U-Bar	301.5	228.6	78.2	50.8	69.9	76.2	95.2	152.2	12.2	110
	1200	5.6		11.87	9.00	3.08	2.00	2.75	3.00	3.75	5.99	0.48	4.33

Dimensions and technical information subject to change without notice.

Series 1117

Specifications

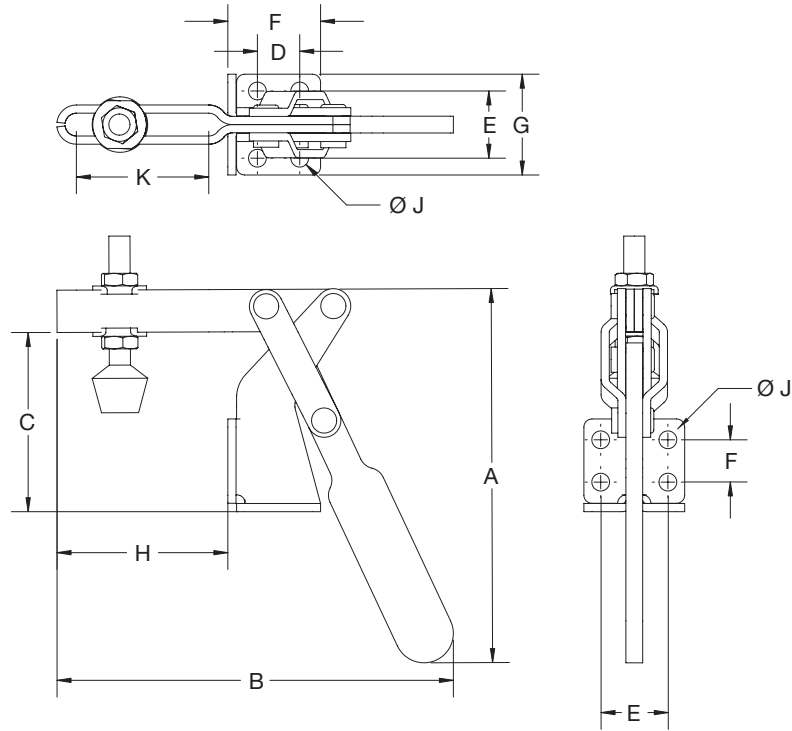
Bar Opens: **180°**Handle Opens: **60°**Spindle Supplied: **5/16-18 x 2.50**

11170CR

Model	Holding Capacity	Weight	Description	A	B	C	D	E	F	G	H	J	K
	N/lb.	Kg/lb.		mm/in.									
11170CR	1670	0.40	Flanged Base, U-Bar	161.8	156.1	71.1	16.0	25.4	35.1	38.1	65.5	6.7	53.6
	375	0.88		6.37	6.14	2.8	0.63	1.00	1.38	1.50	2.58	0.26	2.11

Dimensions and technical information subject to change without notice.

Series 1405

Specifications

Bar Opens:	90°
Handle Opens:	50°
Spindle Supplied:	19420CR

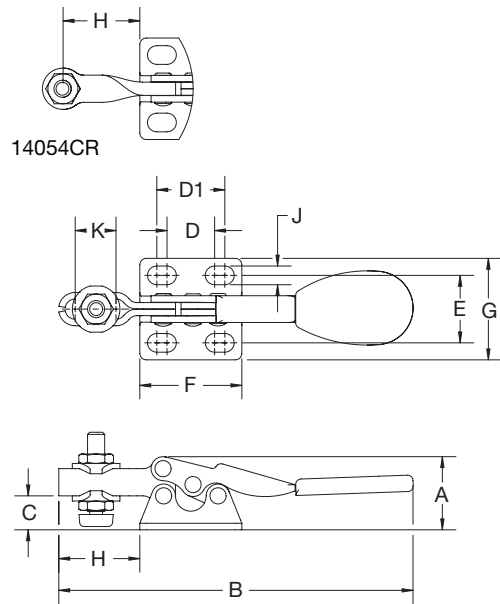
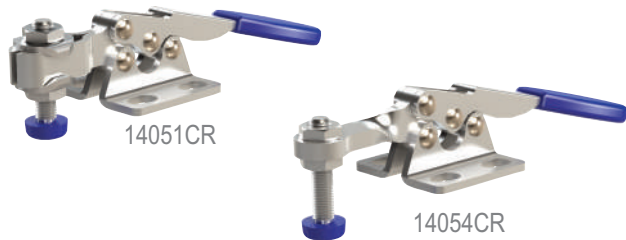

Model	Holding Capacity		Weight	Description	A	B	C	D	D1	E	F	G	H	J	K
	N/lb.	Kg/lb.													
14051CR	270	0.03	0.06	Flanged Base, U-Bar	17.3	82.7	7.4	11.1	16	15.7	23.8	23.7	18.9	4.4	9.5
	60	0.06			0.68	3.26	0.29	0.44	0.63	0.62	0.94	0.93	0.74	0.18	0.37
14054CR	270	0.03	0.06	Flanged Base, Straight Bar	17.3	86.5	9	11.1	16	15.7	23.8	23.7	18	4.4	-
	60	0.06			0.68	3.40	0.35	0.44	0.63	0.62	0.94	0.93	0.71	0.18	-

Series 1415

Specifications

Bar Opens:	84°
Handle Opens:	70°
Spindle Supplied:	19630CR

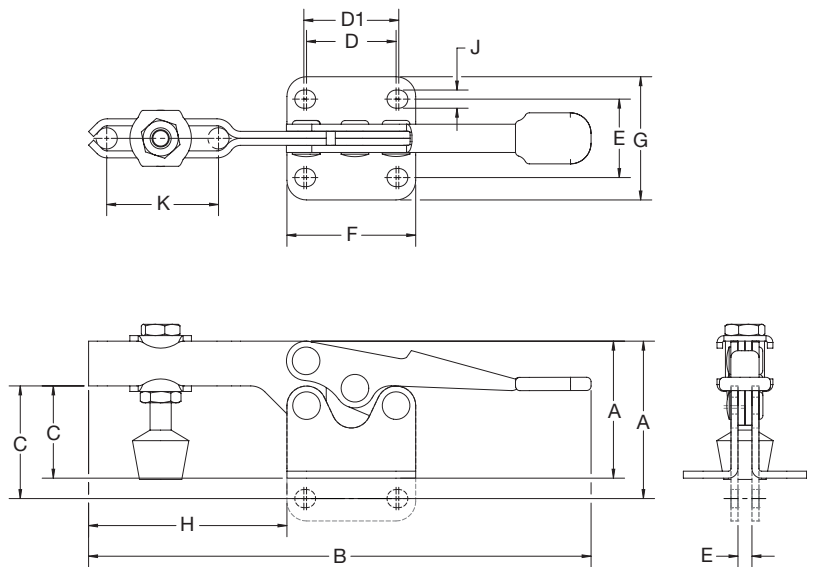

Model	Holding Capacity		Weight	Description	A	B	C	D	D1	E	F	G	H	J	K
	N/lb.	Kg/lb.													
14151CR	890	0.15	0.34	Flanged Base, U-Bar	38.9	142.6	25.6	26.2	26.9	22.3	36.5	35	56.3	5.2	31.1
	200	0.34			1.53	5.61	1.01	1.03	1.06	0.88	1.44	1.38	2.22	0.2	1.23
14152CR	890	0.15	0.34	Straight Base, U-Bar	44.6	142.6	37.7	26.2	26.9	4	36.5	-	56.3	5.2	31.1
	200	0.34			1.76	5.61	1.48	1.03	1.06	0.16	1.44	-	2.22	0.2	1.23

Dimensions and technical information subject to change without notice.

Series 1425

Specifications

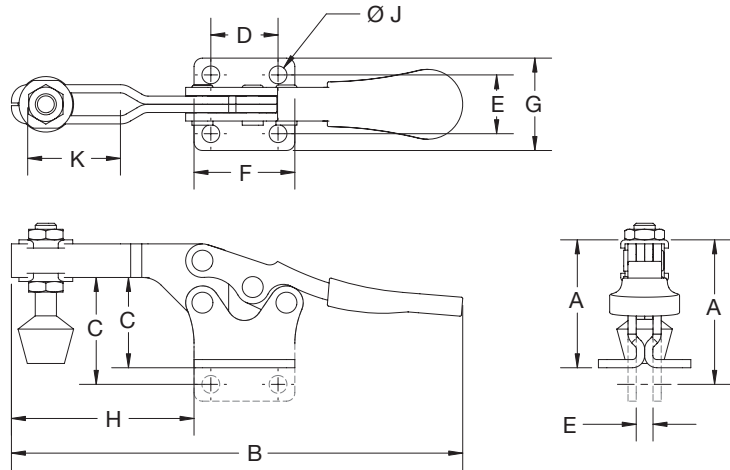
Bar Opens: **92°**Handle Opens: **70°**Spindle Supplied: **19835CR**

Model	Holding Capacity		Weight	Description	A	B	C	D	E	F	G	H	J	K
	N/lb.	Kg/lb.												
14251CR	2220	0.25	0.55	Flanged Base, U-Bar	46.8	170	32.9	25.4	22.1	38.1	34.8	69.2	6.7	35
	500	0.55			1.84	6.69	1.3	1.00	0.87	1.50	1.37	2.72	0.27	1.38
14252CR	2220	0.25	0.55	Straight Base, U-Bar	53.2	170	39.3	25.4	6.2	38.1	-	69.2	6.7	35
	500	0.55			2.09	6.69	1.55	1.00	0.24	1.50	-	2.72	0.27	1.38

Series 1435

Specifications

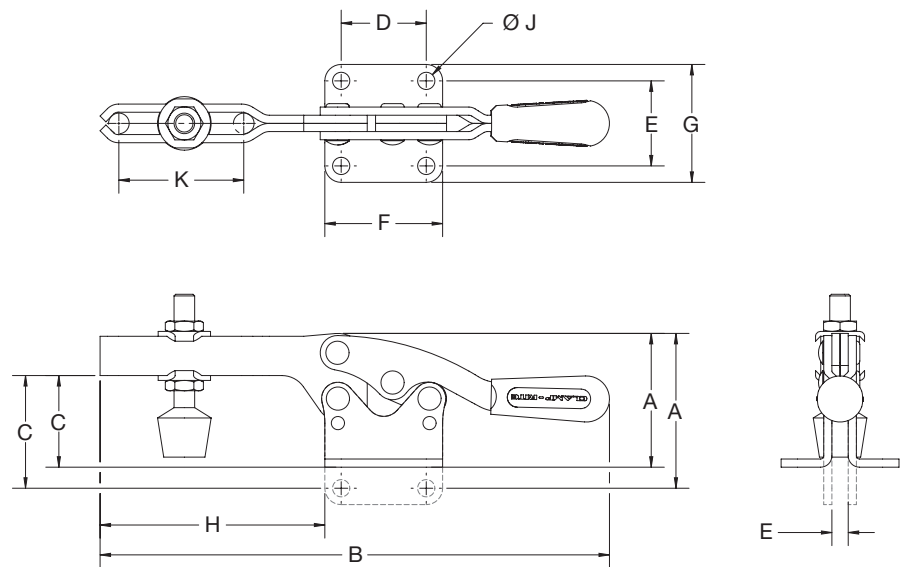
Bar Opens: **92°**Handle Opens: **50°**Spindle Supplied: **19055CR**

Model	Holding Capacity		Weight	Description	A	B	C	D	E	F	G	H	J	K
	N/lb.	Kg/lb.												
14351CR	3340	0.67	1.47	Flanged Base, U-Bar	64.9	247.9	43.3	41.3	41.2	57.2	57.2	109.2	8.4	60.4
	750	1.47			2.55	9.76	1.7	1.63	1.62	2.25	2.25	4.3	0.33	2.38
14352CR	2220	0.25	0.55	Straight Base, U-Bar	75.1	247.9	54.7	41.3	7.9	57.2	-	109.2	8.4	60.4
	500	0.55			2.96	9.76	2.15	1.63	0.31	2.25	-	4.3	0.33	2.38

Dimensions and technical information subject to change without notice.

Series 1605

Specifications

Bar Opens:	90°
Handle Opens:	170°
Spindle Supplied:	#10-42 x 1.38 (16051CR) 5/16-18 x 2.50 (16071CR) 3/8-16 x 3.50 (16091CR)

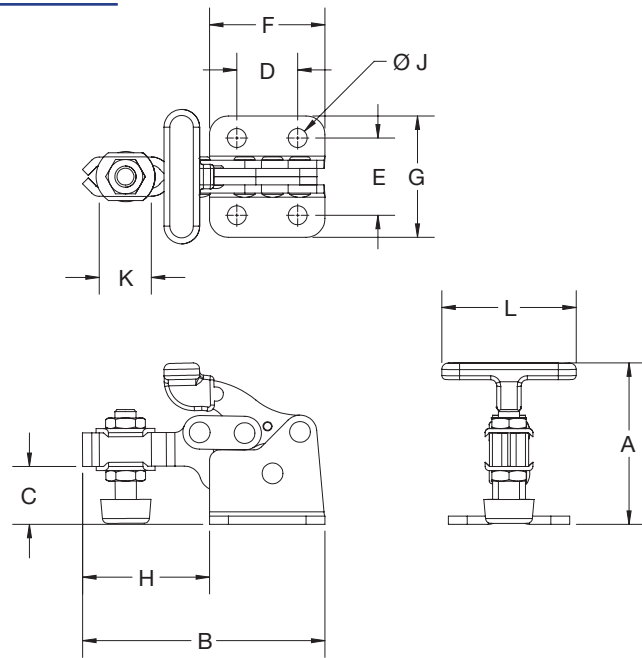

Model	Holding Capacity		Weight	Description	A	B	C	D	E	F	G	H	J	K	L
	N/lb.	Kg/lb.													
16051CR	670	0.06	Flanged Base, U-Bar	37.3	58.4	16.5	13.5	16.8	26.2	26.2	32	4.3	11.2	33.5	
	150	0.13		1.47	2.3	0.65	0.53	0.66	1.03	1.03	1.26	0.17	0.44	1.32	
16071CR	1560	0.24	Flanged Base, U-Bar	61	91.7	22	23	29.2	43.7	45.9	48	7.1	19	51	
	350	0.54		2.40	3.61	0.87	0.91	1.15	1.72	1.81	1.89	0.28	0.75	2.00	
16091CR	3340	0.27	Flanged Base, U-Bar	94.7	135.4	33.3	35.1	38.1	64	64	71.4	7.9	33.5	63	
	750	0.59		3.73	5.33	1.31	1.38	1.5	2.52	2.52	2.81	0.31	1.32	2.48	

Dimensions and technical information subject to change without notice.

Series 1223

Specifications

Drawing Movement:	mm [in.]
12230	46.0 [1.81]
12310	44.5 [1.75]
12410	63.5 [2.50]

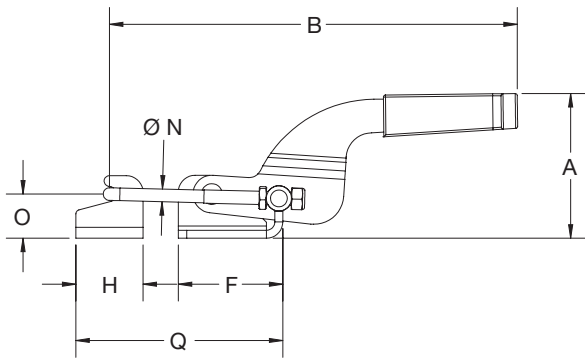
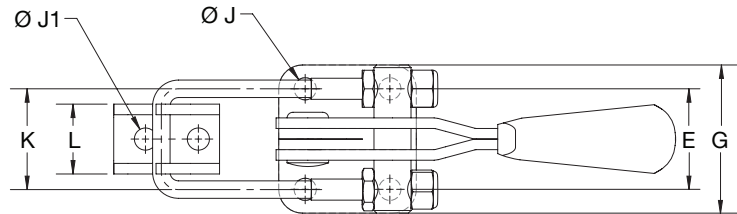
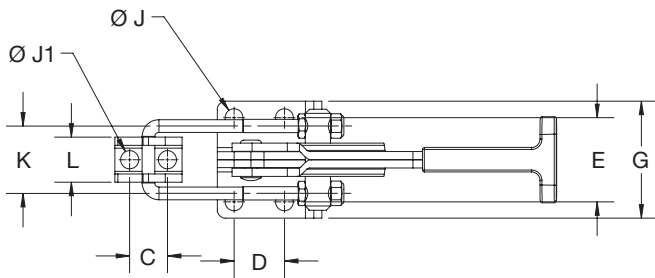

12310CR - 12410CR

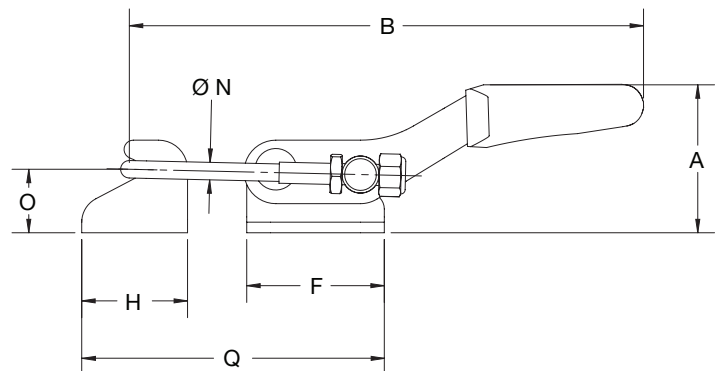

12230CR

Model	Holding Capacity	Weight	A	B	C	D	E	F	G	H	J	J1	K	L	N	O	Q (MIN)	Q (MAX)
12230CR	1600	0.07	28	97.2	10	16	19	26	28	20	4.2	4.2	19	13.2	3.3	12	46	57.2
	360	0.16	1.10	3.83	0.39	0.63	0.75	1.02	1.10	0.79	0.17	0.17	0.75	0.52	0.13	0.47	1.81	2.25
12310CR	3200	0.25	54.5	154.1	14.3	19.1	31.8	39.5	44.1	25.4	6.7	6.9	25.4	17	4.8	16.7	64.9	78.2
	700	0.56	2.15	6.07	0.56	0.75	1.25	1.56	1.74	1.00	0.27	0.27	1.00	0.67	0.19	0.66	2.56	3.08
12410CR	8900	0.65	73.4	188.1	19.1	41.3	38.1	60.5	53.8	38.1	8.5	8.5	44.5	30.1	7.9	23.8	98.6	114.3
	2000	1.43	2.89	7.41	0.75	1.63	1.5	2.38	2.12	1.5	0.33	0.33	1.75	1.19	0.31	0.94	3.88	4.5

Dimensions and technical information subject to change without notice.

Series 1275

Specifications

Drawing Movement: mm [in.]

12750 89 [3.50]

12850 55.6 [2.19]

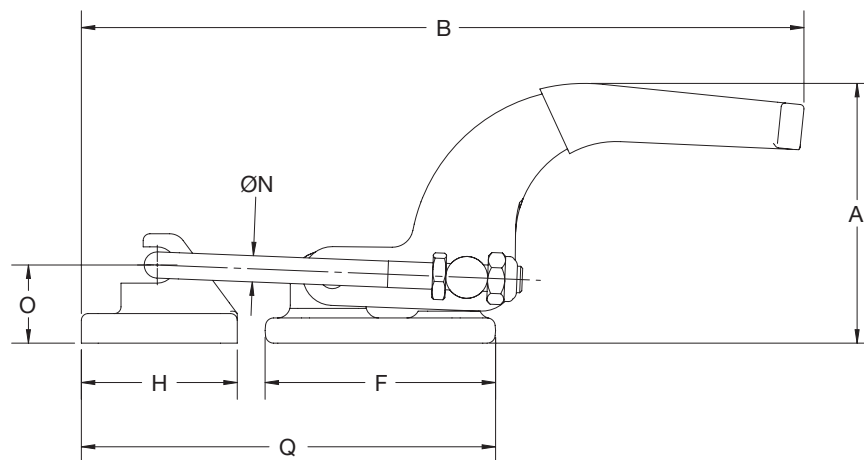
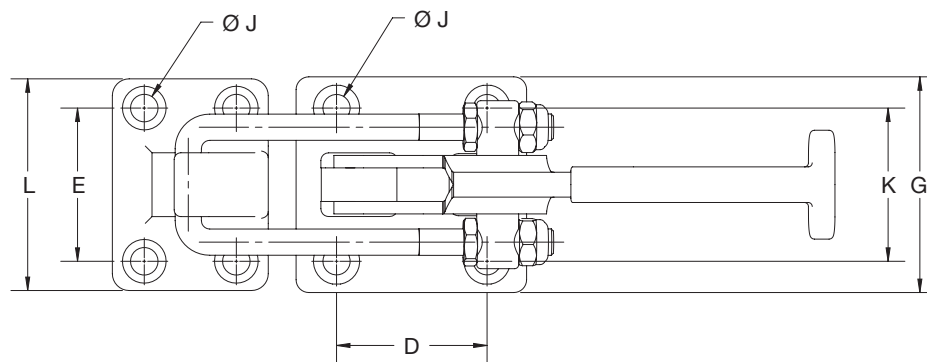
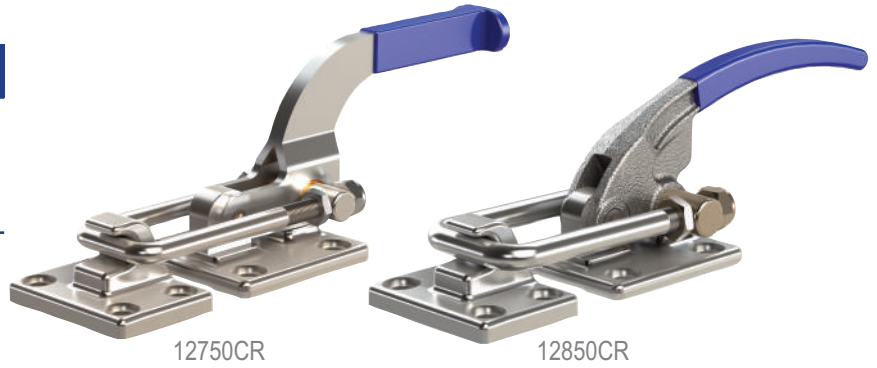

Model	Holding Capacity	Weight	A	B	C	D	E	F	G	H	J	K	L	N	O	Q	
																(MIN)	(MAX)
			mm/in.														
12750CR	17.8kN	1.25	100.6	289.3	34.8	56.9	57.9	87.1	81.5	58.9	10.4	43.4	79.8	9.9	29.7	158	183.1
	4,000	2.78	3.96	11.39	1.37	2.24	2.28	3.43	3.21	2.32	0.41	1.71	3.14	0.39	1.17	6.22	7.21
12850CR	33.3kN	1.47	92.2	300	34.8	56.9	57.4	87.6	81	58.9	9.6	54.8	80.3	11.7	27.4	155.7	184.2
	7,500	3.26	3.63	11.8	1.37	2.24	2.26	3.45	3.19	2.32	0.38	2.16	3.16	0.46	1.08	6.13	7.25

Dimensions and technical information subject to change without notice.

Series 1224

Specifications

Drawing Movement:	mm [in.]
12240	39 [1.53]
12340	51 [2.00]
12440	63.5 [2.50]

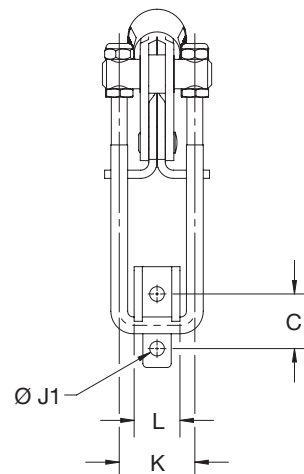
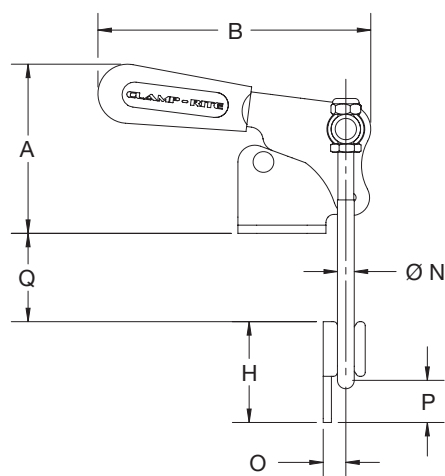
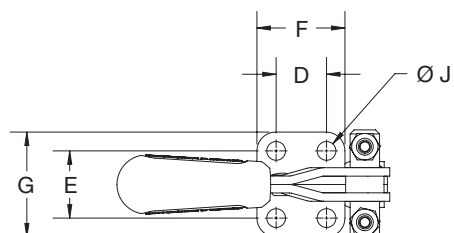

Model	Holding Capacity	Weight	A	B	C	D	E	F	G	H	J	J1	K	L	N	O	P	Q (MIN)	Q (MAX)
12240CR	1.6kN	0.11	51.4	88.3	14.3	12.7	22.4	25.4	35.1	25.4	5.2	4.4	20.6	13.3	3.5	4.7	11.1	12.95	23.4
	360	0.25	2.03	3.48	0.56	0.5	0.88	1.00	1.38	1.00	0.20	0.17	0.81	0.52	0.14	0.19	0.44	0.51	0.92
12340CR	3.1kN	0.27	63.9	103	20.6	19.1	25.4	33.3	39.6	38.1	7.1	5.6	28.6	17.3	6.4	8.8	16.7	16	34.1
	700	0.55	2.52	4.06	0.81	0.75	1.00	1.31	1.56	1.50	0.28	0.22	1.13	0.68	0.25	0.35	0.66	0.63	1.34
12440CR	8.9kN	0.70	91.4	133.4	26.9	31.8	37.3	47.2	53.6	54.1	8.6	8.9	44.2	30.2	7.9	12.7	20.1	54.4	53.6
	2,000	1.54	3.60	5.25	1.06	1.25	1.47	1.86	2.11	2.13	0.34	0.35	1.74	1.19	0.31	0.50	0.79	2.14	2.11

Dimensions and technical information subject to change without notice.

Series 1251

Specifications

Drawing Movement: mm [in.]

12510	101.6 [4.00]
12515	101.6 [4.00]
12710	136.6 [5.38]
12810	155.7 [6.13]



12510CR



12515CR

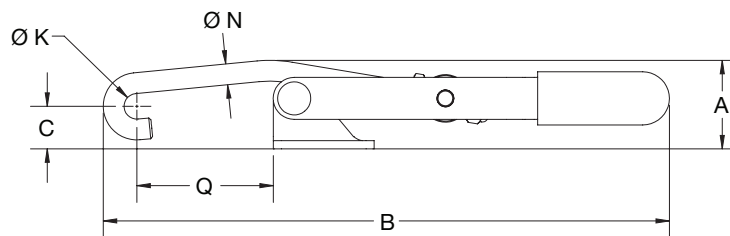
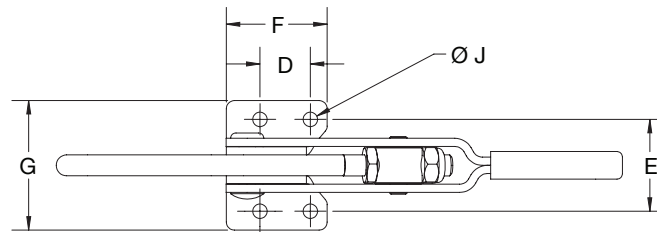

Model	Holding Capacity		Weight	A	B	C	D	E	F	G	J	K	N	Q (MIN)	Q (MAX)
	N/lb.	Kg/lb.													
12510CR	1670	0.28	32.9	214	15.5	19.1	34.7	38.1	48.9	5.5	9.7	7.9	43.6	54.6	
	375	0.61	1.29	8.42	0.61	0.75	1.37	1.50	1.93	0.22	0.38	0.31	1.72	2.15	
12515CR	1670	0.28	35.7	216.9	17.3	38.1	-	50.8	14.2	6.7	9.7	7.9	30.9	42.4	
	375	0.61	1.41	8.54	0.68	1.50	-	2.00	0.56	0.27	0.38	0.31	1.22	1.67	
12710CR	3340	0.62	55.1	298.5	34.5	31.8	49	47.2	66.3	8.9	12.7	9.5	68.6	87.4	
	750	1.38	2.17	11.75	1.36	1.25	1.93	1.86	2.61	0.35	0.50	0.37	2.70	3.44	
12810CR	4450	1.12	64.3	350.5	39.6	28.7	63.2	54.1	89	10	14.7	13	69.9	91.4	
	1000	2.49	2.53	13.80	1.56	1.13	2.49	2.13	3.50	0.39	0.58	0.51	2.75	3.60	

Dimensions and technical information subject to change without notice.

Series 1201

Specifications

Drawing Movement: mm [in.]

12010CR 101.6 [4.00]

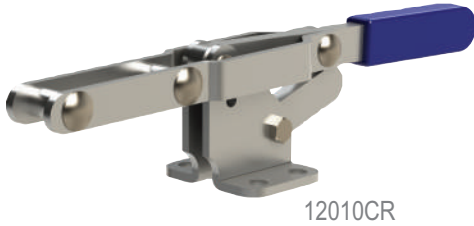

12010CR

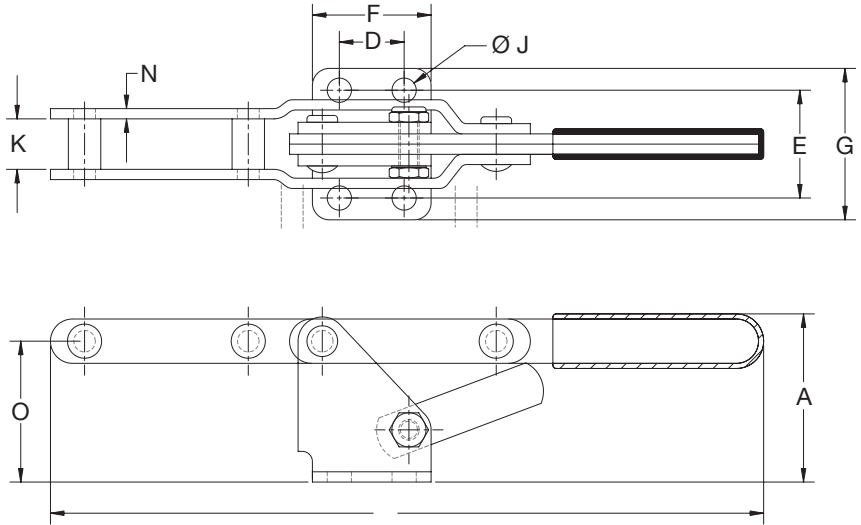

Model	Holding Capacity	Weight	A	B	D	E	F	G	J	K	N	O
	N/lb.	Kg/lb.	mm/in.									
12010CR	1670	0.31	47.8	213.4	19	31	35.1	43.7	7.1	14.2	3	40.4
	375	0.68	1.88	8.4	0.75	1.22	1.38	1.72	0.28	0.56	0.12	1.59

Push/Pull Toggle Clamps

Series 1301

Model	Plunger Travel	Spindle Supplied
	mm/in.	
13010CR	16 0.63	19105CR

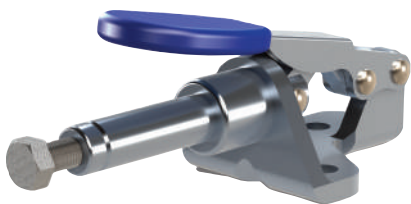

13010CR

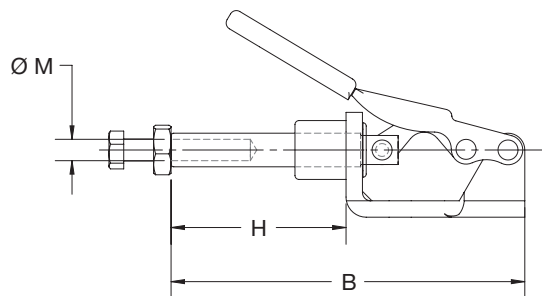
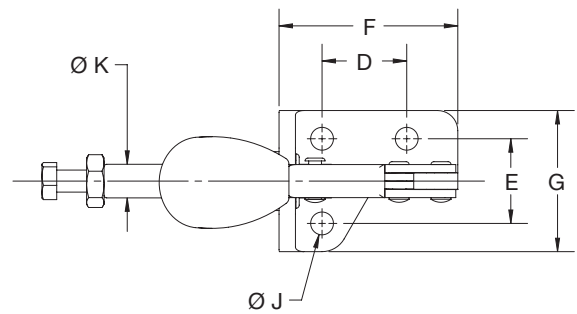
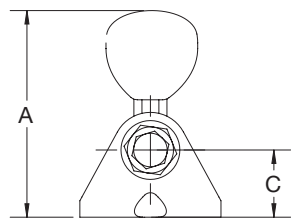

Model	Holding Capacity	Weight	Description	A	B	C	D	E	F	G	J	K	M
	N	Kg		mm/in.									
13010CR	440	0.04	Flanged Base, Imperial Thread	39.1	66.9	12.7	16	16	33.8	26.7	4.3	6.2	#8-32
	100	0.09		1.54	2.63	0.5	0.63	0.63	1.33	1.05	0.17	0.25	

Dimensions and technical information subject to change without notice.

Series 1302

Model	Plunger Travel mm/in.	Spindle Supplied
13020CR	19 0.75	19145CR
13040CR	57.2 1.50	19518CR
13240CR	66.7 2.63	19381CR

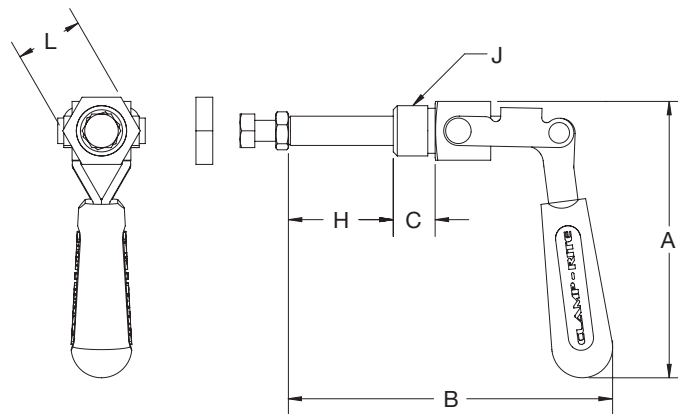
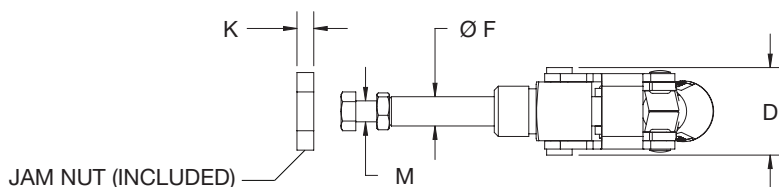

13040CR

Model	Holding Capacity	Weight	Description	A	B	C	D	F	H	J	K	L	M
Metric	N	Kg		mm									
13020CR	900	0.05	Through Hole Mount, Imperial Thread	79.8	66.1	12.7	26.2	10	20.6	5/8-18	6.4	22.4	1/4 - 20
	200	0.12		3.14	2.6	0.5	1.03	0.39	0.81				
13040CR	1330	0.20	Through Hole Mount, Imperial Thread	106.3	123.3	19.4	33.1	11.1	36.1	3/4-16	6.4	25.4	5/16 - 18
	300	0.44		4.18	4.85	0.76	1.3	0.44	1.42				
13240CR	3100	0.70	Through Hole Mount, Imperial Thread	137.9	170.9	22.4	47.2	16	71.1	1-14	8.1	41	3/8-16
	700	1.54		5.43	6.73	0.88	1.86	0.63	2.8				

Dimensions and technical information subject to change without notice.

Series 1305

Model	Plunger Travel	Spindle Supplied
	mm/in.	
13050CR	31.8 1.25	19518CR



13050CR

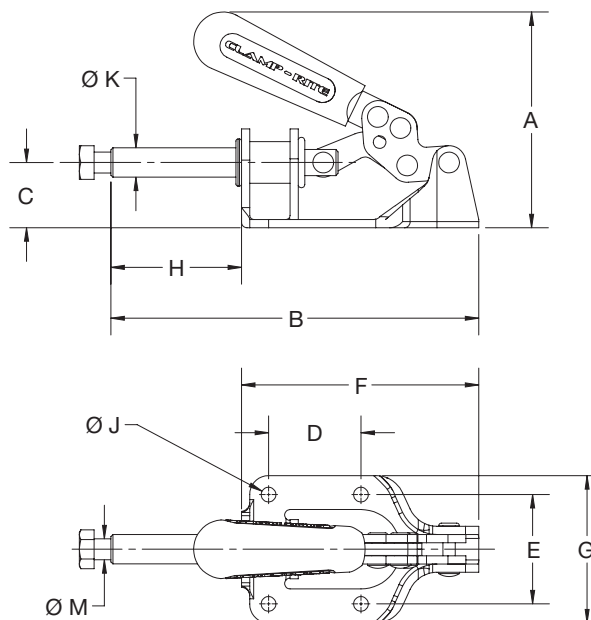

Model	Holding Capacity	Weight	Description	A	B	C	D	E	F	G	J	K	M
Metric	N	Kg		mm									
13050CR	1330 300	0.31 0.69	Flanged Base, Imperial Thread	79.8 3.14	138.4 5.45	24.9 0.98	35.1 1.38	41.7 1.64	90.2 3.55	56.4 2.22	48.3 1.90	5.6 0.22	5/16-18

Series 1303

Model	Plunger Travel	Spindle Supplied
	mm/in.	
13030CR	38.1 1.25	19518CR
13485CR	41.9 1.65	19381CR

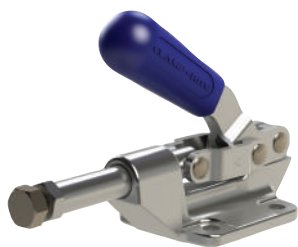

13030CR

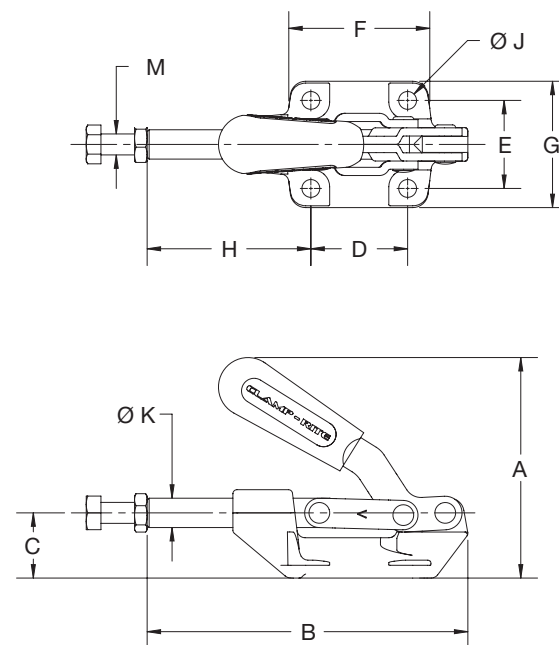

Model	Holding Capacity	Weight	Description	A	B	C	D	E	F	G	H	J	K	M
Metric	N	Kg		mm										
13030CR	2670 600	0.32 0.7	Flanged Base, Imperial Thread	83.3 3.28	121.2 4.77	24.6 0.97	36.6 1.44	33.3 1.31	53.3 2.10	47.8 1.88	61.9 2.44	6.8 0.27	11.1 0.44	5/16-18
13485CR	3780 850	0.58 1.28	Flanged Base, Imperial Thread	97 3.82	159.3 6.27	31.8 1.25	41.1 1.62	41.4 1.63	59.2 2.33	57.2 2.25	90.5 3.56	8.4 0.33	15.6 0.62	3/8-16

Dimensions and technical information subject to change without notice.

Series 1309

Model	Plunger Travel	Spindle Supplied
	mm/in.	
13090CR	31.8 1.25	19518CR



13090CR

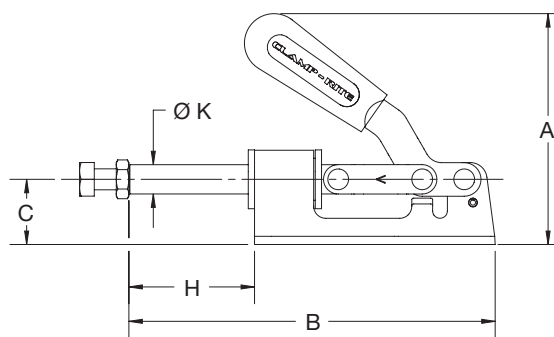
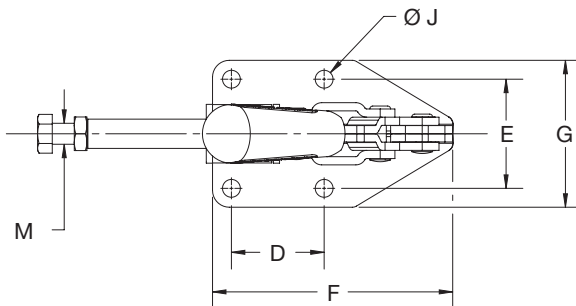

Model	Holding Capacity	Weight	Description	A	B	C	D	E	F	G	H	J	K	M
Metric	N	Kg		mm										
13090CR	1330 300	0.40 0.88	Flanged Base, Imperial Thread	84 3.31	138.6 5.46	24.6 0.97	35.1 1.38	41.2 1.62	91 3.58	55.5 2.19	47.6 1.87	6.6 0.27	12.7 0.50	5/16-18

Series 1310

Model	Plunger Travel	Spindle Supplied
	mm/in.	
13100CR	41.4 1.63	3/8-16 x 1.25

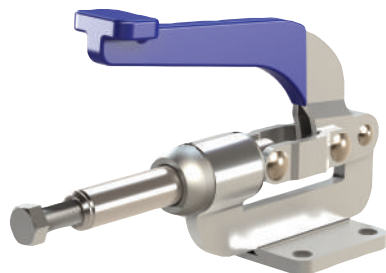

13100CR

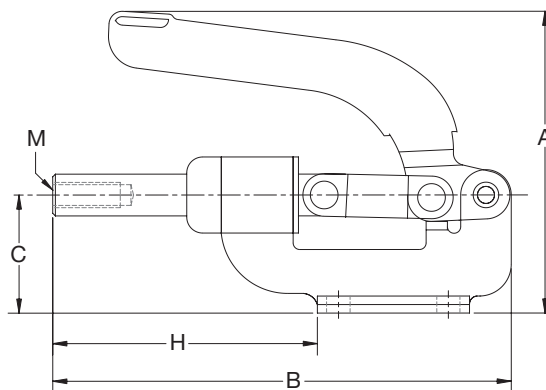
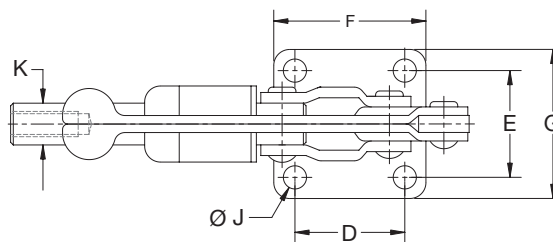

Model	Holding Capacity	Weight	Description	A	B	C	D	E	F	G	H	J	K	M
Metric	N	Kg		mm										
13100CR	3560 800	0.8 1.76	Flanged Base, Imperial Thread	128 5.04	173.2 6.82	44.5 1.75	41.4 1.63	40.1 1.58	57.2 2.25	55.9 2.2	107.4 4.23	8.6 0.34	15.7 0.62	3/8-16

Dimensions and technical information subject to change without notice.

Series 1307

Model	Plunger Travel mm/in.	Spindle Supplied
13070CR	41.2 1.62	19518CR
13300CR	50.8 2.00	19381CR

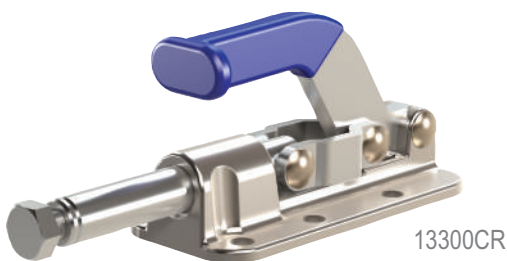
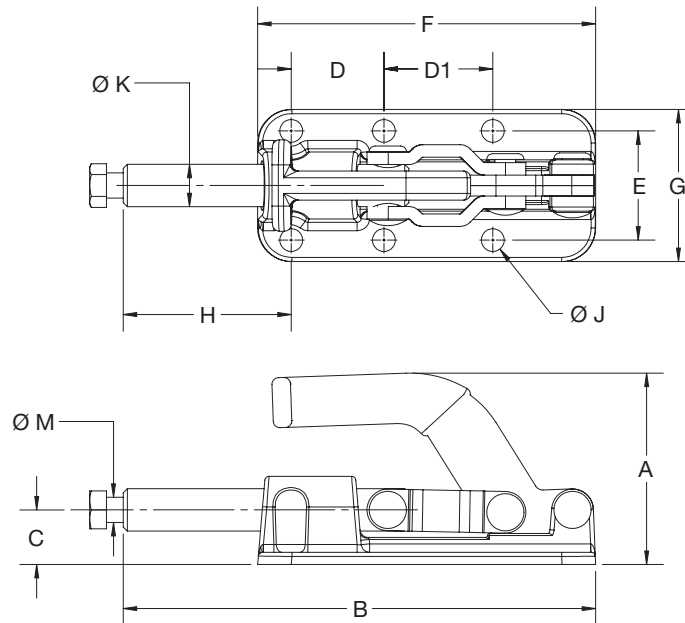

Model	Holding Capacity	Weight	Description	A	B	C	D	D1	E	F	G	H	J	K	M
Metric	N	Kg		mm											
13070CR	3560	0.76	Flanged Base, Imperial Thread	83.3	155	17.3	35	41.1	41.1	109.2	55.4	62.7	7.1	12.5	5/16-18
	800	1.7		3.28	6.1	0.68	1.38	1.62	1.62	4.3	2.18	2.47	0.28	0.49	
13300CR	11.1kN	0.92	Flanged Base, Imperial Thread	72.3	178.6	20.6	35.1	41.1	41.3	127.8	57.5	63.5	8.6	16	3/8-16
	2500	2.06		2.85	7.03	0.81	1.38	1.62	1.63	5.03	2.27	2.50	0.34	0.63	

Dimensions and technical information subject to change without notice.

Accessories

Flat Cushion Tip Bonded Cap Spindle (includes two jam nuts)

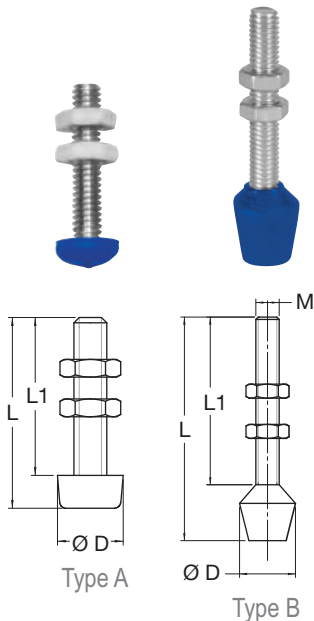

Model	D	M	L	L1	Type
mm/in.					
19218CR	16 0.63	1/4-20	54.1 2.13	40.1 1.58	B
19316CR	21 0.83	5/16-18	76.2 3.00	58.2 2.29	B
19312CR	22.2 0.88	3/8-16	89.0 3.50	63.5 2.50	B

Model	D	M	L	L1	Type
mm/in.					
19420CR	.8 0.31	M4X0.7	22 0.87	20 0.78	A
19525CR	10 0.39	M5X0.8	29 1.14	25 0.98	A
19836CR	19 0.75	M8X1.25	45.3 1.78	32.6 1.28	A
19630CR	16 0.63	M6X1.0	44 1.73	30 1.18	B
19835CR	21 0.83	M8X1.25	53 2.09	35 1.38	B
19055CR	26 1.02	M10X1.5	79 3.11	55 2.17	B

Standard Adjustable Spindle (includes two jam nuts)

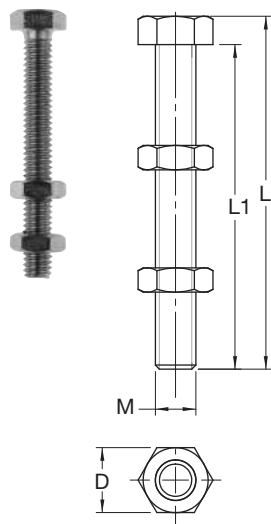

Model	D	M	L	L1
mm/in.				
19105CR *	6.4 0.25	#8-32	21.8 0.86	19 0.75
19145CR	11.2 0.44	1/4-20	20.4 0.80	16 0.63
19518CR	12.7 0.50	5/16-18	31 1.22	25.4 1.00
19381CR	14.2 0.56	3/8-16	38.1 1.50	31.8 1.25
19310CR	19 0.75	1/2-13	84 3.31	76.2 3.00
19450CR	19 0.75	1/2-13	122.2 4.81	114.3 4.50

Model	D	M	L	L1
mm/in.				
19421CR *	7 4.77	M4 x 0.7	21.8 0.86	19 0.75
19616CR	10 0.39	M6 x 1.0	22 0.87	20 0.78
19825CR	13 0.51	M8 x 1.25	29 1.14	25 0.98
19103CR	17 0.67	M10 x 1.5	43 1.69	35 1.38

* Material: Nylon

Bolt Retainer

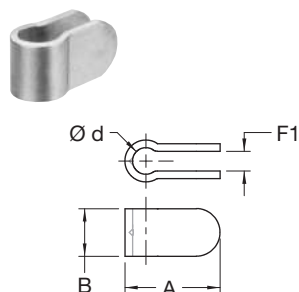

Model	A	B	F1	d
mm/in.				
19516CR	30.5 1.20	16.3 0.64	6.4 0.25	8.1 0.32
19380CR	16.3 37.3	18.8 0.74	8.4 0.33	10.4 0.41
19120CR	43.2 1.70	30.2 1.19	9.7 0.38	17.0 0.67

Dimensions and technical information subject to change without notice.



Tel: 1-855-326-4428

E-mail: marketing.na@clamp-rite.com

www.clamp-rite.com